

FEATURES

- Vent hole for drain
- Backelite cover on handle

APPLICATION

- Hydraulic machines
- Isolation for gauges
- Compressors

All Stainless Steel Design



STANDARD SPECIFICATIONS

Type	: Pattern 1 (2 Way)
Material	: AISI 316 SS
Instrument connection	: 1/2" NPT (F) [1/2" NPT (F) x 2 Nos for 3 Way]
	: 1/2" BSP (F) [1/2" BSP (F) x 2 Nos for 3 Way]
Process connection	: 1/2" NPT (M) / 1/2" BSP (M)
Handle	: AISI 304 SS with Backelite cover
Gaskets / Seals	: PTFE
Maximum working pressure	: 100 bar
Maximum working temperature	: 180°C

DIMENSIONAL DRAWING

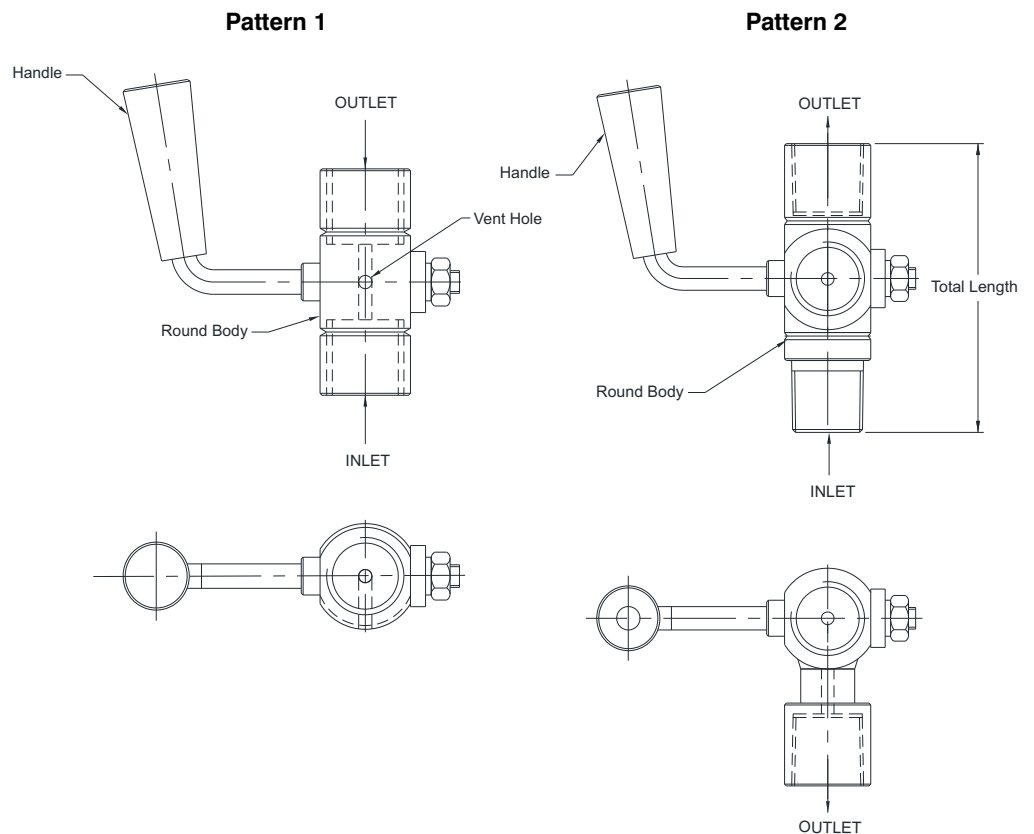

ORDERING CODES

1. TYPE

- | | |
|---|-------------------|
| 1 | Pattern 1 (2 Way) |
| 2 | Pattern 2 (3 Way) |

1

2. MATERIAL

- | | |
|----|--------------|
| MC | AISI 304 SS |
| MF | AISI 316 SS |
| MG | AISI 316L SS |

MF

3. INSTRUMENT CONNECTION

- | | |
|-----|--------------|
| 12B | 1/4" BSP (M) |
| 13B | 3/8" BSP (M) |
| 14B | 1/2" BSP (M) |
| 12N | 1/4" NPT (M) |
| 13N | 3/8" NPT (M) |
| 14N | 1/2" NPT (M) |
| 02B | 1/4" BSP (F) |
| 03B | 3/8" BSP (F) |
| 04B | 1/2" BSP (F) |
| 02N | 1/4" NPT (F) |
| 03N | 3/8" NPT (F) |
| 04N | 1/2" NPT (F) |

04N

4. PROCESS CONNECTION

- | | |
|-----|--------------|
| 12B | 1/4" BSP (M) |
| 13B | 3/8" BSP (M) |
| 14B | 1/2" BSP (M) |
| 12N | 1/4" NPT (M) |
| 13N | 3/8" NPT (M) |
| 14N | 1/2" NPT (M) |
| 02B | 1/4" BSP (F) |
| 03B | 3/8" BSP (F) |
| 04B | 1/2" BSP (F) |
| 02N | 1/4" NPT (F) |
| 03N | 3/8" NPT (F) |
| 04N | 1/2" NPT (F) |

14N

5. OTHER OPTIONS

- | | |
|----|----------------------------------|
| TC | Material test certificate 3.1 |
| TM | Material test certificate 2.2 |
| TO | Certification for Oxygen service |
| XM | Marking by engraving |
| XL | Marking by laser |

XM

Ordering Example : A101-1-MF-04N-14N-XM