

## FEATURES

- Laser welded diaphragm
- Optional flushing ring
- Optional exotic materials

## APPLICATION

- Separation systems
- Isolation applications
- Viscous & corrosive media
- High-pressure applications
- High vibration application

### Insert Diaphragm



### STANDARD SPECIFICATIONS

Range type	: -1...0 bar to 0...250 bar
Top chamber material	: AISI 304 SS
Diaphragm	: AISI 316L SS
Gaskets	: PTFE
Flange material	: AISI 316 SS
Instrument connection	: 1/2" NPT (F) / 1/2" BSP (F)
Sealing fluid	: Silicon DC 200 (-40...205°C)
Process connection	: Flange as per ANSI B16.5 / EN1092-1 / JIS B 2210
Flange facing type	: Raised face
Assembly	: Direct

### DIMENSIONAL DRAWING

Type S26

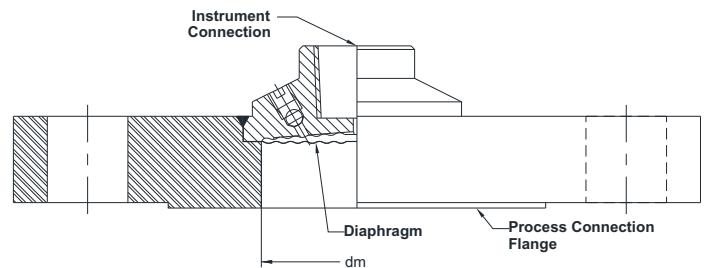

Type S27

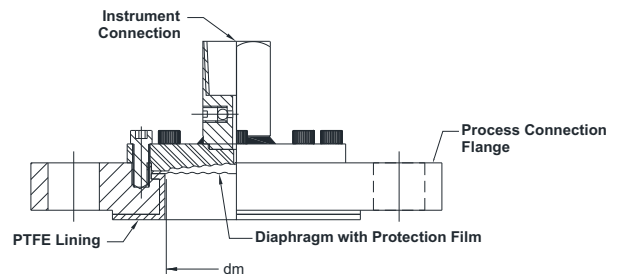

Type S28

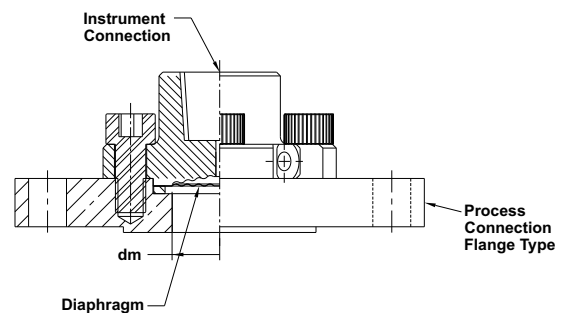

ORDERING CODES

1. RANGE TYPE

<b>S26</b>	-1...0 bar & 0...250 bar (Non PTFE lined)
<b>S27</b>	-1...0 bar & 0...40 bar (PTFE lined)
<b>S28</b>	-1...0 bar & 0...40 bar

S26

2. TOP CHAMBER MATERIAL

<b>LB</b>	ASTM A105	<b>LC</b>	AISI 304 SS
<b>LF</b>	AISI 316 SS	<b>LG</b>	AISI 316L SS

LC

3. DIAPHRAGM MATERIAL

<b>DG</b>	AISI 316L SS	<b>DM</b>	Monel 400
<b>DO</b>	Hastelloy C-276	<b>DV</b>	Titanium
<b>DW</b>	Tantalum	<b>D8</b>	Silver coated
<b>D2</b>	PTFE		

DG

4. GASKETS (for S27 & S28)

<b>RP</b>	PTFE	<b>RM</b>	Metal
-----------	------	-----------	-------

RP

5. FLANGE MATERIAL

<b>NB</b>	ASTM A105	<b>NC</b>	AISI 304 SS
<b>NF</b>	AISI 316 SS	<b>NG</b>	AISI 316L SS
<b>NM</b>	Monel 400	<b>NO</b>	Hastelloy C-276
<b>NV</b>	Titanium	<b>NW</b>	Tantalum

NF

6. INSTRUMENT CONNECTION

<b>03B</b>	3/8" BSP (F)	<b>04N</b>	1/2" NPT (F)
<b>02B</b>	1/4" BSP (F)	<b>04B</b>	1/2" BSP (F)
<b>02N</b>	1/4" NPT (F)		

04N

7. SEALING FLUID

<b>OA</b>	Silicon DC 200 [-40°C to 205°C]
<b>OF</b>	Food grade oil [-20°C to 140°C]
<b>OG</b>	Glycerine [10°C to 150°C]
<b>OI</b>	Syltherm 800 [-40°C to 315°C]
<b>OL</b>	Silicon DC 710 [7°C to 371°C]

OA

8. PROCESS CONNECTION

<b>XXX</b>	Refer Flange Table for the codes
------------	----------------------------------

A25

9. FLANGE FACING

<b>F</b>	Flat Face
<b>J</b>	Ring-Type Joint
<b>R</b>	Raised Face
<b>T</b>	Tongue and Groove (T&G)

R

10. COUPLING FLANGES & HARDWARES

<b>LD</b>	AISI 304 SS	<b>LH</b>	AISI 316 SS
-----------	-------------	-----------	-------------

LA

11. PROTECTION ON WETTED PARTS

<b>PA</b>	PTFE lining on bottom chamber / Flange
<b>PB</b>	PTFE protection for diaphragm
<b>PC</b>	PTFE coating on diaphragm or wetted parts

XX

12. ASSEMBLY

<b>B8</b>	Direct
<b>B9</b>	Remote (capillary)

B8

13. CAPILLARY

<b>OU</b>	AISI 304 SS	<b>OV</b>	AISI 316 SS
-----------	-------------	-----------	-------------

XX

14. ARMOUR

<b>OX</b>	AISI 304 SS	<b>OY</b>	AISI 316 SS
<b>OZ</b>	PVC (Ambient max. 60°C)		

XX

15. REMOTE MOUNTING LENGTH

<b>XXXX</b>	1000 mm up to 6000 mm
-------------	-----------------------

XXXX

16. OTHER OPTIONS

<b>XZ</b>	Dry seal
<b>HL</b>	Helium leak test
<b>TM</b>	Material test certificate 2.2
<b>TC</b>	Material test certificate 3.1

XX

Ordering Example : D203-S26-LC-DG-RP-NF-04N-OA-A25-R-LA-XX-B8

APPLICABLE ACCESSORIES

<b>A301</b>	Flushing Ring
-------------	---------------

MOUNTING KITS

<b>Hardware</b>	Bolt / Nut / Washer	<b>Flanges</b>	Suitable mating type
<b>Gaskets</b>	Metal / Graphoil		

NOTES:

- Other sealing liquids are available, contact factory for further details.
- With PTFE lining please select coupling Flanges & Hardware.
- All metal diaphragms are laser welded to the Top Chamber.